

## Installation Manual

# DIAS 1500

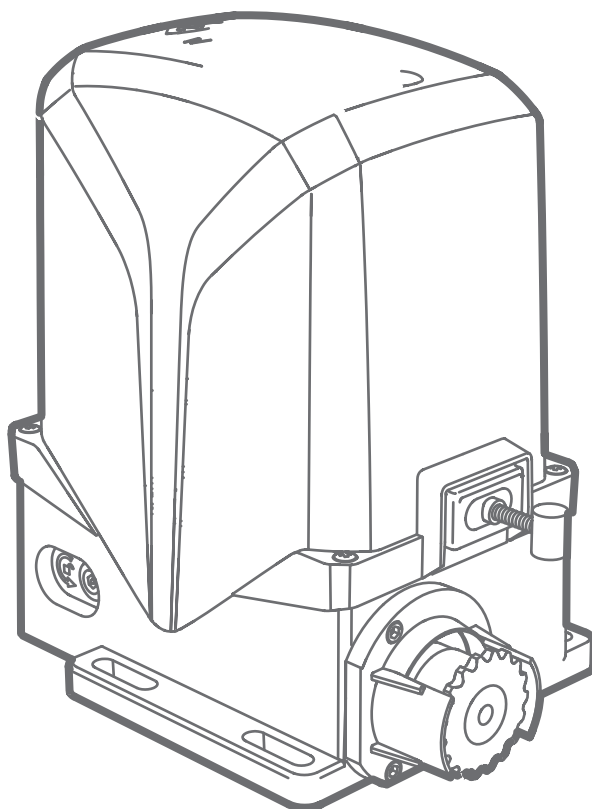

**OPENER FOR RACK-DRIVEN  
SLIDING MOTOR**

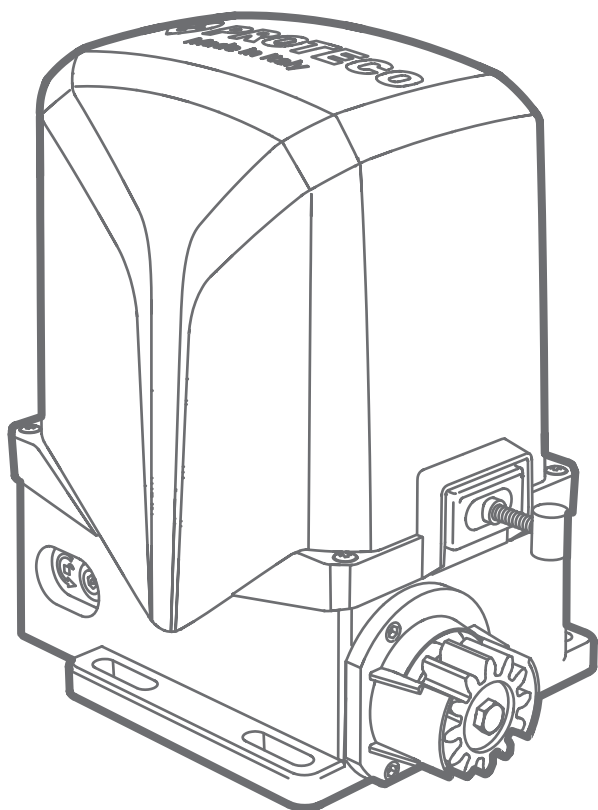
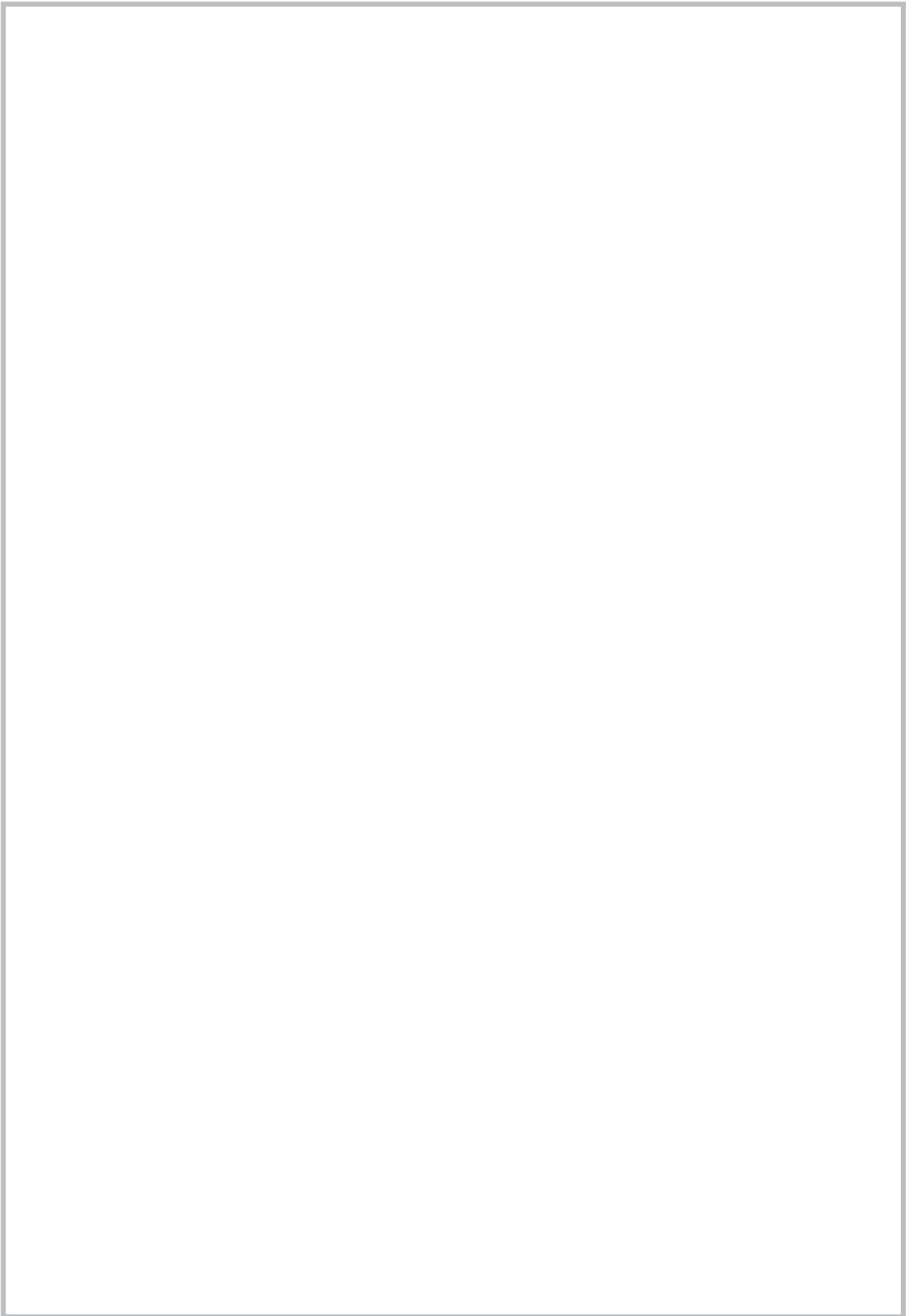

# Index

<b>1.</b>	<b>WARNINGS AND GENERAL SAFETY INSTUCTIONS</b> .....	<i>pag. 01</i>
	<b>DICHIARAZIONE DI CONFORMITA'</b> .....	<i>pag. 01</i>
<b>2.</b>	<b>PRODUCT DESCRIPTION AND INTENDED USE</b> .....	<i>pag. 01</i>
2.1	<b>TECHNICAL SPECIFICATIONS</b> .....	<i>pag. 02</i>
2.2	<b>PACK CONTENTS</b> .....	<i>pag. 02</i>
2.3	<b>DIMENSIONS</b> .....	<i>pag. 02</i>
<b>3.</b>	<b>INSTALLATION</b> .....	<i>pag. 03</i>
3.1	<b>Preliminary Checks</b> .....	<i>pag. 03</i>
3.2	<b>Preliminary Checks</b> .....	<i>pag. 03</i>
	3.2.1 <b>STANDARD INSTALLATION</b>	
	3.2.2 <b>ELECTRICAL CABLES SPECIFICATIONS</b>	
3.3	<b>Preliminary installation work and masonry for anchor plate</b> .....	<i>pag. 04</i>
3.4	<b>Installation of the gear motor</b> .....	<i>pag. 04</i>
3.5	<b>Assembling the rack</b> .....	<i>pag. 05</i>
	3.5.1 <b>Installing the Toothed Rack B117</b>	
	3.5.2 <b>Welding Metal Toothed Rack B102</b>	
3.6	<b>Welding Metal Toothed Rack B102</b> .....	<i>pag. 06</i>
	3.6.1 <b>PVC brackets for Toothed Rack B117</b>	
	3.6.2 <b>Universal steel brackets</b>	
3.7	<b>Assembling the chain</b> .....	<i>pag. 07</i>
	3.7.1 <b>Limit-brackets fixing for chain-driving motor</b> .....	<i>pag. 08</i>
<b>4.</b>	<b>ELECTRICAL WIRING</b> .....	<i>pag. 08</i>
<b>5.</b>	<b>START-UP</b> .....	<i>pag. 08</i>
<b>6.</b>	<b>RELEASE PROCEDURE FOR MANUAL OPERATION</b> .....	<i>pag. 09</i>
6.1	<b>How to unlock the motor for manual operating</b>	
6.2	<b>How to restore the automatic working</b>	
<b>7.</b>	<b>MAINTENANCE</b> .....	<i>pag. 09</i>
<b>8.</b>	<b>DISPOSAL</b> .....	<i>pag. 09</i>

# 1. WARNINGS AND GENERAL SAFETY INSTRUCTIONS

This manual contains important safety information.

An incorrect installation or an improper use may cause serious damages to persons or objects.

Read this manual carefully and completely. Pay particular attention to the sections marked by the symbol: 

This indicates that risk to personal injury may occur if not adhered to.

Store this manual safely for future use.



**Always disconnect main power supply before operating in the automatic gate.  
Make sure that the earth system is perfectly working and always connect the automatic gate to it.**

The installation of automatic gates and doors must fully comply with the requirements set forth in 2006/42/EC Directive, with particular reference to EN 12445 and EN 12453 standards.

The final connection to the electrical mains, testing and start-up of the automation must be performed by skilled and qualified personnel (professional gate installers), who is responsible for carrying out the risks analysis and verifying the compliance of the system with the current safety standards.

This product is exclusively designed and manufactured for the intended use specified in this manual.

Any other use than stated could compromise the integrity and the safety of the product and therefore is strictly prohibited.

The automation is designed to move driveway gates and not intended to be used for any other purpose.



**Do not let children play with the radio transmitters and any other device which could accidentally start the gate automation.**

Use exclusively original parts by manufactured by Proteco for maintenance.

Do not carry out any alteration on the components of the automatic gate.

Proteco SRL will not accept liability for any components and/or additional devices used in-conjunction with the automation that has not been produced exclusively by Proteco.

## EU DECLARATION OF CONFORMITY AND DECLARATION OF INCORPORATION OF PARTLY COMPLETED MACHINERY

In accordance with Annex II B of Machinery Directive 2006/42/CE  
The legal representatives of



Proteco S.r.l.  
via Neive 77, 12050 Castagnito (CN) Italia  
tel (+39) 0173210111 - fax (+39) 0173210199  
www.proteco.net - info@proteco.net

hereby declare that the products listed below:

MOVER 5, MOVER 6, MOVER 8, MOVER 15, CAT 5, CAT 8  
MOVER 5 110V, MOVER 8 115V, MOVER 15 115V, CAT 5 115V, CAT 8 115V  
**Electromechanical gearmotor for rack/chain-driven sliding gate and accessories**

**comply the following Essential Requirements of directive 2006/42/CE Allegato I (direttiva Macchine):**

1.1.2 - 1.1.3 - 1.1.5 - 1.2.1 - 1.2.2 - 1.2.3 - 1.2.6 - 1.3.2 - 1.3.4 - 1.3.9 - 1.4.1 - 1.4.2.1 - 1.5.1 - 1.5.4 - 1.5.6 - 1.5.8 - 1.5.13 - 1.6.1 - 1.6.4 - 1.7.1 1.7.3 1.7.4

are in conformity with the following directives:

**2014/30/UE (EMC)  
2011/65/CE (RoHS2)  
2014/35/UE (LVD)**

The above listed products are delivered, limitedly to the applicable parts, according to the following standards:

- **EN 12453** Industrial, commercial and garage doors and gates. Safety in use power operated doors. Requirements.
- **EN60335-1** Household and similar electrical appliances - Safety - Part 1: General requirements.
- **EN60335-2-103** Household and similar electrical appliances - Safety - Part 2-103: Particular requirements for drives for gates, doors and windows.

They also state that:

- the relevant technical documentation is compiled in accordance with part B of Annex VII of directive 2006/42/CE
- the relevant technical documentation is compiled and preserved by Proteco S.r.l.  
Which undertakes to transmit it by mail in response to a reasoned request by the national authorities.
- the partly completed machinery must not be put into service until the final machinery into which it is to be incorporated has been declared in conformity with the provisions of the directive 2006/42/CE

Castagnito, 20/01/2020

**Marco Gallo**  
Managing Director



## 2. PRODUCT DESCRIPTION AND INTENDED USE

MOVER gear motor is designed to automate residential or commercial sliding gate with rack.

Any other use than above described has to be considered as inappropriate and strictly prohibited.

All models feature an irreversible gearing system that locks the gate when it is in its fully closed position.

Therefore no additional lock is needed.

In case of a power failure the motor lock can be released to move the gate manually (see section 6).

## 2.1 Technical Specifications

Power supply	230V-50-60Hz
Current	3A
Motor power	600 W
Capacitor	20 µF
Thermic protection	150°C
Max thrust	1000 N
IP class protection	44
Revolution speed	1400 rpm
Opening speed	8,5 m/min
Max gate weight	1500 Kg
Duty cycle	40%

## 2.2 PACK CONTENTS

### DIAS

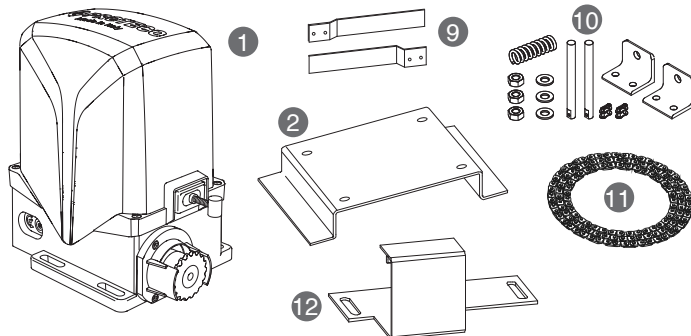
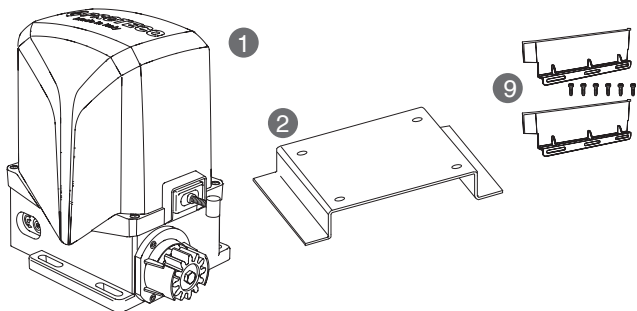

### Fixing pack

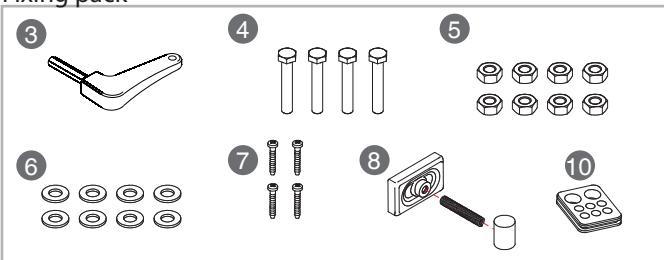

### Fixing pack

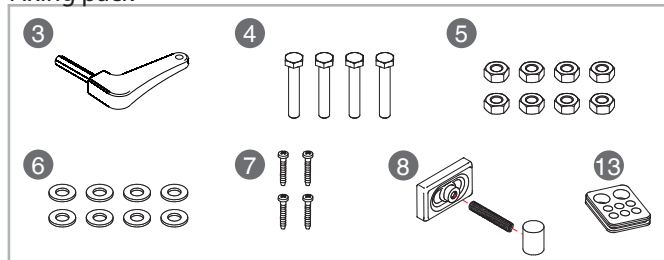

1	Gear-motor Mover
2	MPIS01 Anchor plate
3	SCH0190 Release key
4	MVI1060AZ Galvanized M10x60 bolts to fasten the motor
5	MDAM10Z Nut Ø10 for motor-anchor plate fixing
6	MRO10Z Washer Ø10 for motor-anchor plate fixing
7	Screw M5x25 for cover
8	MSPM01 Rubber protection
	MMO02 Spring
	MMA01 Cilinder
10	MPC06 Cable grommet SH70
9	MSLF01S/D Limit switch brackets and screws

1	Gear-motor Cat
2	MPIS01 Motor bracket
3	SCH0190 Release key
4	MVI1060AZ Screw M10x60 for motor-anchor plate fixing
5	MDAM10Z Nut Ø10 for motor-anchor plate fixing
6	MRO10Z Washer Ø10 for motor-anchor plate fixing
7	Screw M5x25 for cover
8	MSPM01 Rubber protection
	MMO02 Spring
	MMA01 Cilinder
13	MPC06 Cable grommet SH70
9	SSLF0370 Limit switch brackets
10	SSAS02 Fixing kit for chain
11	MCT02 Chain 3/8 inches
12	SPIS0370 Chain railing

## 2.3 DIMENSIONS

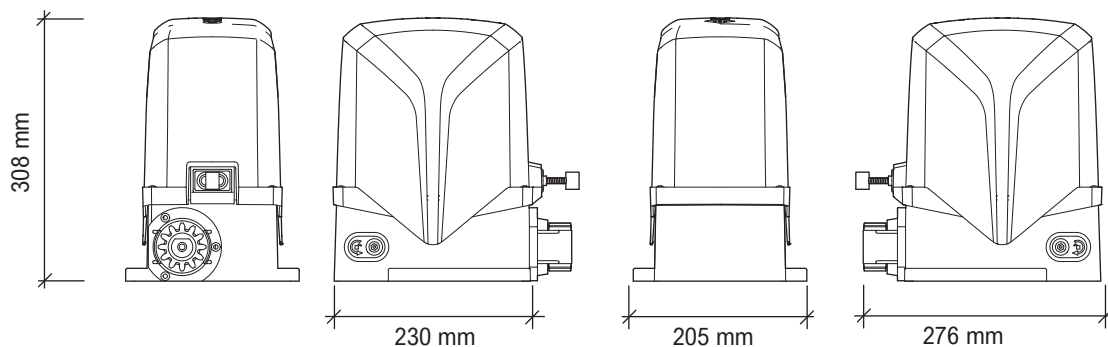

## 3. INSTALLATION

### 3.1 Preliminary Checks

Before the installation, to ensure correct working of the automation, please check the followings:

- Make sure the gate's structure is suitable to be automated
- Check the weight, dimensions and type of the gate is appropriate to this type of automation.
- Ensure the gate is able to open and close smoothly and is free of obstacles that may cause the gate to derail.
- Check the ground and all surfaces for the installation are suitable for stable and safe fixing of the gate automation.
- Make sure the installation area for the automation is wide enough to accommodate the anchor plate and that the motor can be accessed easily in the event of power cuts.
- Ensure the location where the automation is installed is not exposed to flood hazards; if in doubt raise the automation above ground level.
- In cases where the automation has to be installed in a vehicles path or parking area, it is recommended to protect it against accidental damage.
- Ensure an efficient earth connection system is in place.
- Make sure the surfaces for photocells fixing areas are flat and smooth enough to allow a perfect alignment between transmitting and receiving units. They must both directly see each other as they are not reflective.

### 3.2 Electrical Set-up

#### 3.2.1 STANDARD INSTALLATION

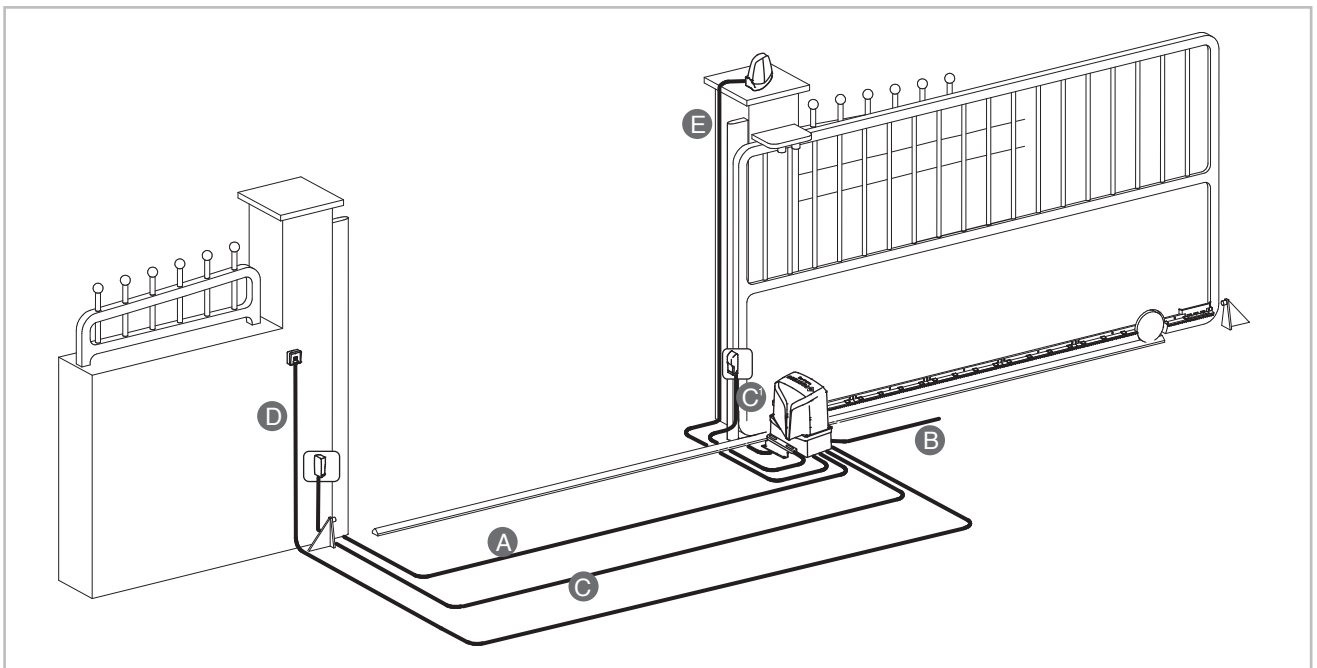

#### 3.2.2 ELECTRICAL CABLES SPECIFICATIONS

The cables required the electrical set-up (not included in the pack) may vary according to quantity and type of devices installed.

230V		
A	Safety edge	2x0,50 mm <sup>2</sup>
B	Power supply	2x1,50+T
C	Photocells	rx 4x0,50 mm <sup>2</sup>
C'	Photocells	tx 2x0,50 mm <sup>2</sup>
D	Key-switch	2x0,50 mm <sup>2</sup>
E	Flashing light	2x0,50 mm <sup>2</sup>

### 3.3 Preliminary installation work and masonry for anchor plate

Check the fixing height of the rack on the gate and calculate the height of concrete base for the motor accordingly

- Dig the foundation pit for the gear motor whilst considering the anchor plate dimensions.  
Give an extra 5cm area extra on each side.  
Pay attention to measurements shown in Fig 2.
- Provide one or more ducts for the electrical cables so that they can reach the motor slot just out of the anchor plate.
- Set concrete into the pit. Ensure this is level and smooth out the surface.  
Wait for the concrete to get solidify (this may take a few days). (Fig. 2)
- Fix the plate to the concrete using suitable plugs. Please refer to Fig. 3 recommended distance.
- Cut the cable ducts above the anchor plate level and route the cables for accessories and electrical mains wiring.  
Let the cables run at least 30-50cm out from the ducting to allow easy wiring to the control panel.

Fig. 2

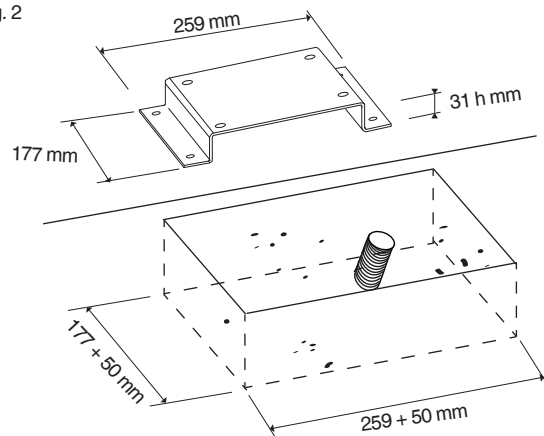
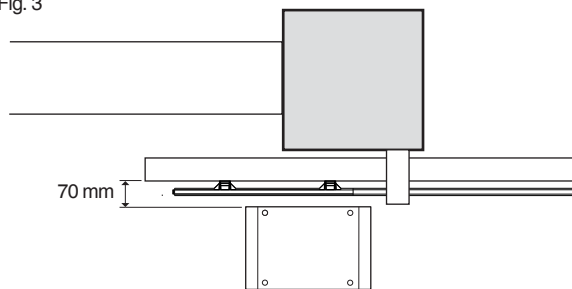

Fig. 3



### 3.4 Installation of the gear motor

- Fix the motor to the anchor plate using the M10 screws, washers and nuts provided as shown in Fig. 5 so that an height adjustment from 15 to 30mm is possible (Fig. 6).
- Use a spirit-level to make sure that the gear motor is perfectly level (Fig. 7 and 8), if it is not adjust the four grub screws accordingly and then tighten the M10 screws.  
Apply the lock-nuts on both sides of the motor base (Fig. 8).
- Release the gear motor for manual operation as illustrated in section 6 of this manual.

Fig. 4

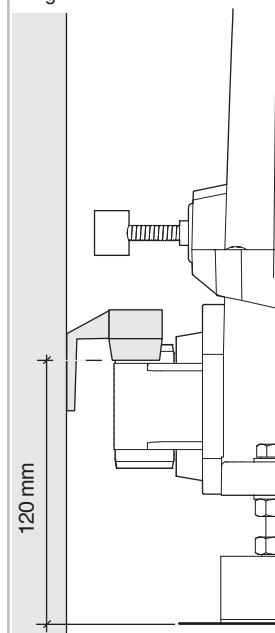

Fig. 5

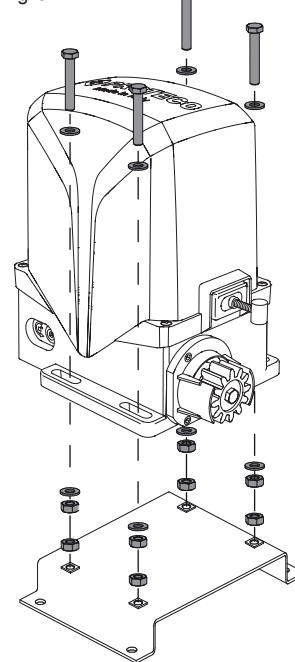

Fig. 6

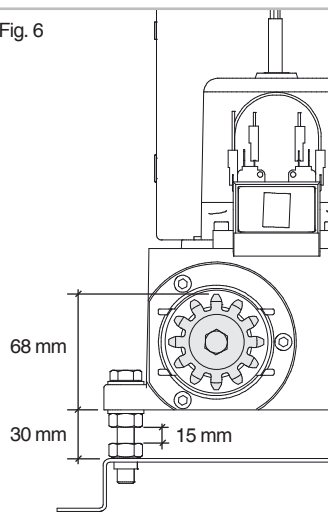

Fig. 7

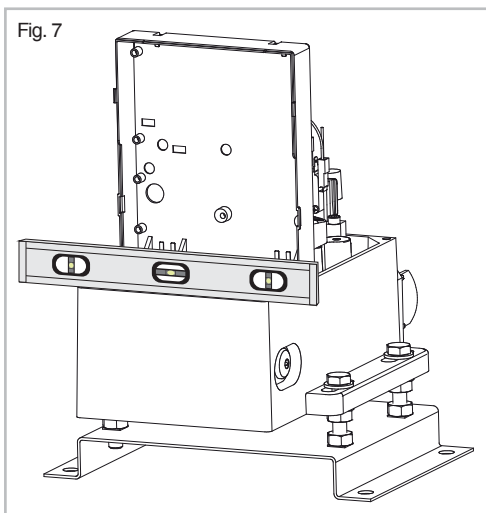
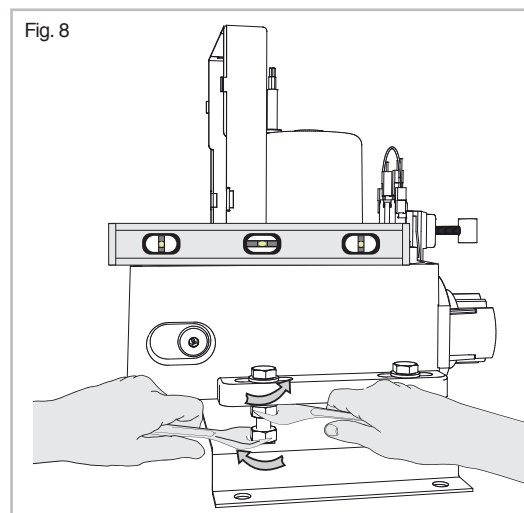

Fig. 8



### 3.5 Assembling the rack

#### 3.5.1 Installing the Toothed Rack B117 – PVC rack M4 20x26mm with inner steel frame (0.5m sections)

- Move the gate manually to its open position.
- Align the first section of the rack to the gate edge and lower it on the pinion. Use a spirit-level to make sure it is perfectly straight.
- Fix this first section of rack to the gate with the provided self-tapping screws. Fix the screws in the middle of the slot as illustrated (Fig. 9).
- Close the gate manually for about ½ meter, join the second section of rack to first one and place it on the motor drive pinion cog.
- Keep the rack perfectly flat and fix it to the gate.
- Repeat the same procedure until the gate is fully covered.
- In case the last section of rack partially comes out from the rack edge, do not cut it. Add a bracket as a gate extension to support the last bit of rack (Fig.10).
- Now, to prevent the gate weights on the pinion, tighten the 4 fixing points of the motor to lower it for 1-2 mm and the fasten the lock-nuts.

Fig. 9

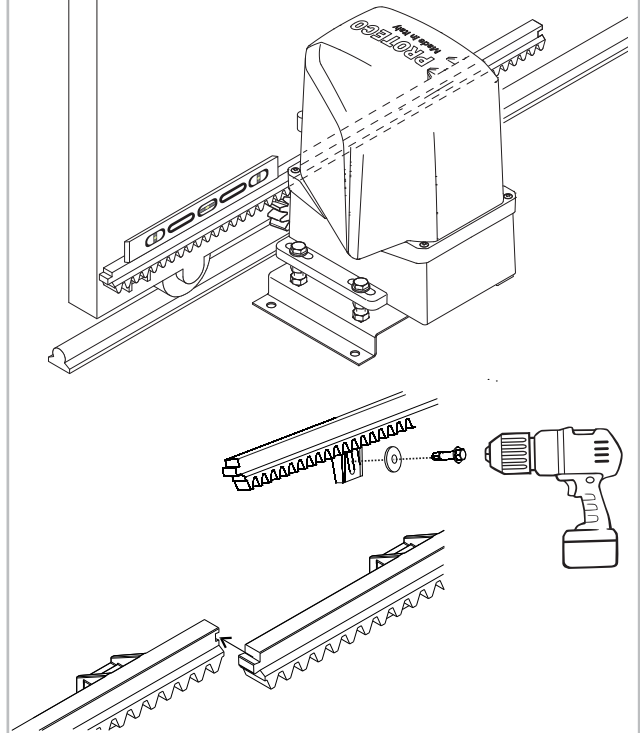

Fig. 10



#### 3.5.2 Welding Metal Toothed Rack B102 – steel rack M4 12x30mm (1m sections)

- Move the gate manually to its open position.
- Assemble the three threaded stand-offs on the first section of rack, positioning in the middle of the slot (Fig. 11).
- Align the first section of the rack to the gates edge and lower it on the pinion. Use a spirit-level to ensure the rack is perfectly straight and level.
- Weld the threaded stand-off to the gate (Fig. 12)
- Move the gate manually, checking that the rack is always resting on the motors drive pinion cog, and weld second and third stand-offs.
- Place the second section of rack side by side with the first one, using an upside-down section of rack to synchronise the rack teeth as illustrated in Fig. 13.
- Move the gate manually and weld the three threaded stand-offs.
- Repeat the same procedure until the gate is fully covered.
- In case the last section of rack partially comes out from the rack edge, do not cut it. Add a bracket as a gate extension to support the last bit of rack (Fig.10).
- Now, to prevent the gate weights on the pinion, tighten the 4 fixing points of the motor to lower it for 1-2 mm and the fasten the lock-nuts.

Fig. 11

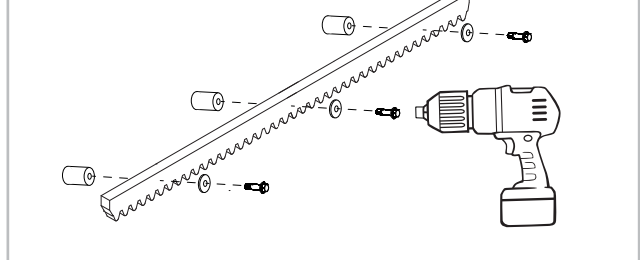

Fig. 12

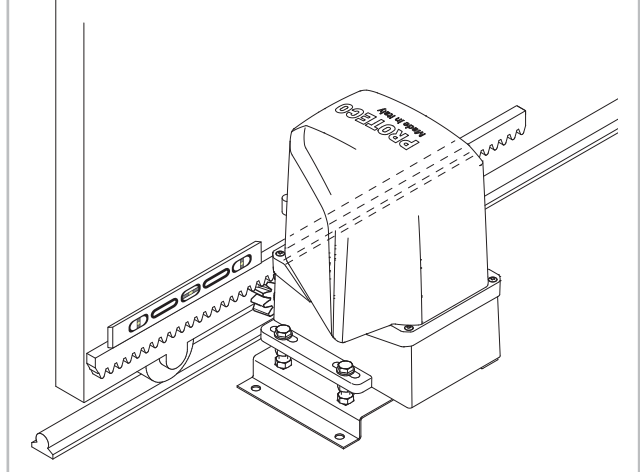
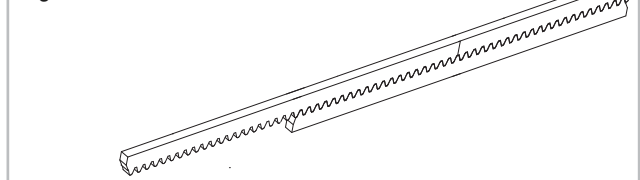

Fig. 13



Check the gate always reaches the mechanical stops keeping the alignment between the rack and the motor drive pinion cog. Ensure that there are no friction points in the gates complete travel.



### 3.6 Assembling the limit-switch brackets

#### 3.6.1 PVC brackets for Toothed Rack B117

- Identify closing and opening brackets according to the motor position against the gate (Fig. 14).
- Manually close the gate up to 3cm before the closing mechanical stop.
- Place the closing bracket on the rack and slide it until the limit-switch is activated (Fig. 15).
- Mark the bracket position onto the rack, slightly open the gate and fix the bracket to the rack.
- Manually open the gate (gate end aligned to the pillar edge).
- Place the opening bracket on the rack and slide it until the limit-switch is activated (Fig. 16).
- Mark the bracket position onto the rack, slightly close the gate and fix the bracket to the rack.

Fig. 14

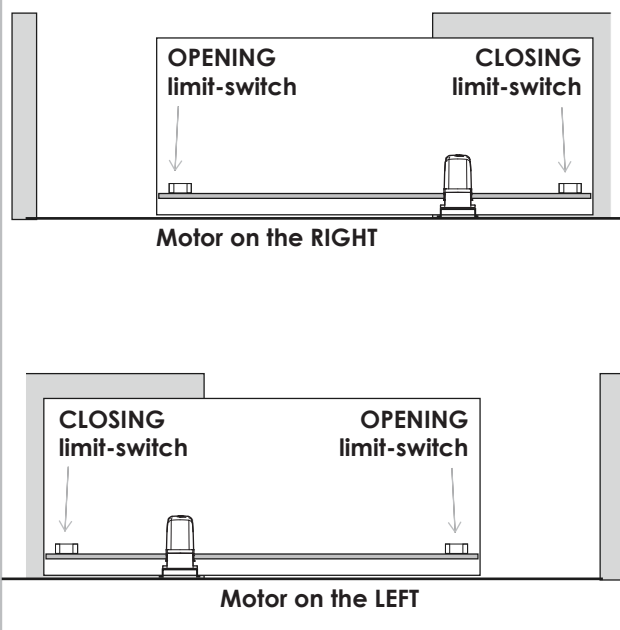

Fig. 15

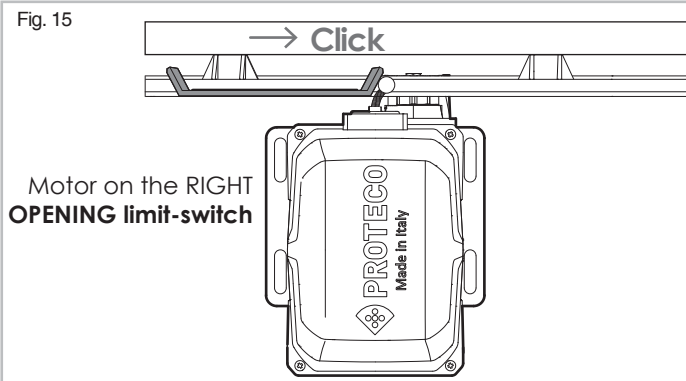
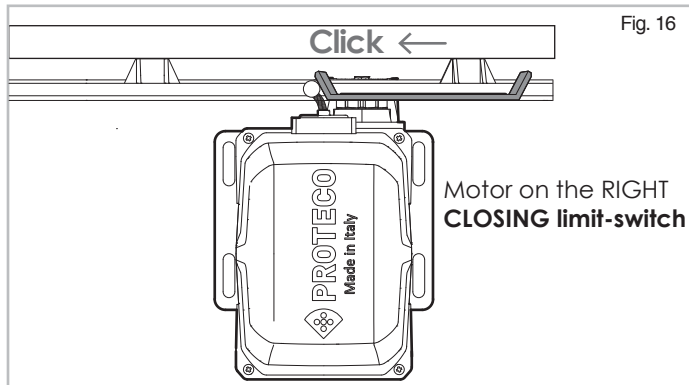

Fig. 16



Once the assembling of the limit brackets to rack is completed, open and close the gate manually to check that the brackets always activate the limit-switch system before the gate reaches its mechanical stops. This checking is important to preserve the correct working of the automation and continued good mechanical condition of the gate.

#### 3.6.2 Universal steel brackets

- Identify closing and opening bracket according to the motor position against the gate (Fig. 17).
- Manually close the gate up to 3cm before the closing mechanical stop.
- Place the two screw fixings loosely on the closing limit bracket.
- Place the closing bracket on the rack and slide it until the limit-switch is activated (Fig. 18).
- Screw the two screws tightly to anchor the bracket onto the rack.
- Manually open the gate (gate end aligned with the edge of the pillar).
- Place the two screws fixings loosely on the opening limit bracket.
- Place the opening bracket on the rack and slide it until the limit-switch is activated (Fig. 19).
- Screw the two screws tightly to anchor the bracket onto the rack.

Fig. 17

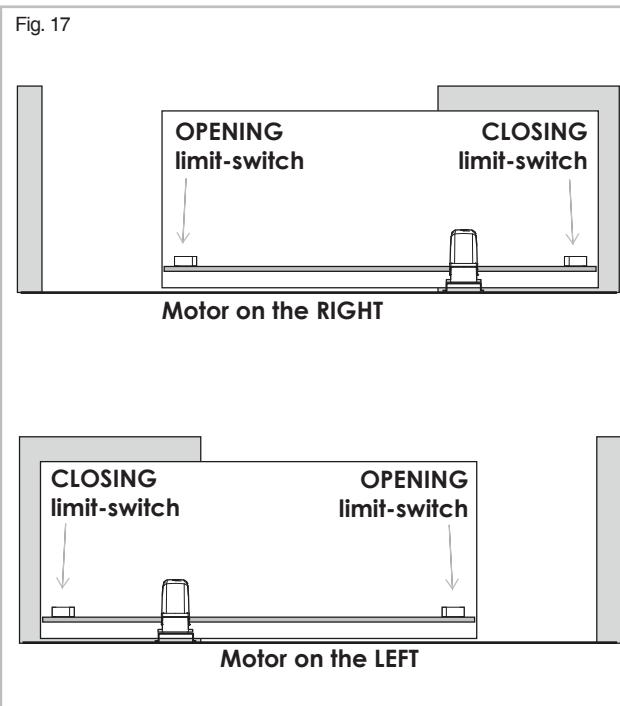

Fig. 18

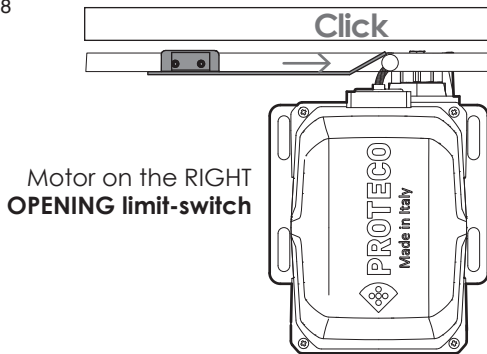
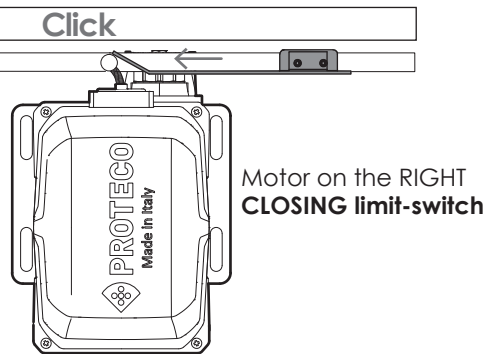

Fig. 19



Once the assembling of the limit brackets to rack is completed, open and close the gate manually to check that the brackets always activate the limit-switch system before the gate reaches its mechanical stops. This checking is important to preserve the correct working of the automation and continued good mechanical condition of the gate.

### 3.7 Assembling the chain

Please use the brackets provided in the pack to fix the chain to the gate.

- Fix the chain-holding brackets on the gate ends as shown in Fig. 20.
- Fasten the first thread bar to the bracket using the nuts and washers provided as shown in Fig. 21. Make sure that the holed end of the bar is facing to the motor.
- Fix the second threaded bar and the spring to the other bracket using the provided nut and washer as shown in Fig. 23. Again make sure that the holed end of the bar is facing to the motor.
- Place the chain on the gate to calculate suitable length and then cut it so you can fasten the chain to the two bars.
- Fasten the chain to the first bar using the joint as in Fig. 21. Release the motor (please refer to section 6 of this manual) and insert the chain in the railing bracket between the motor's pinion and the metal cylinder (Fig. 24). Run the chain to the second bar.
- Fasten the chain to the second bar using the joint. Strain the chain by tightening the bolts on both bars. The chain tightening is good if when the chain is pressed, no matter where, the spring can still compress.

Fig. 20

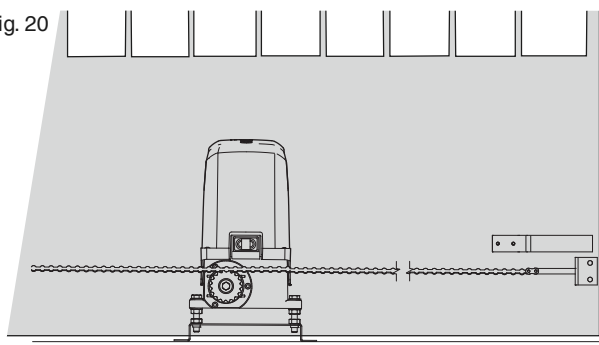

Fig. 21

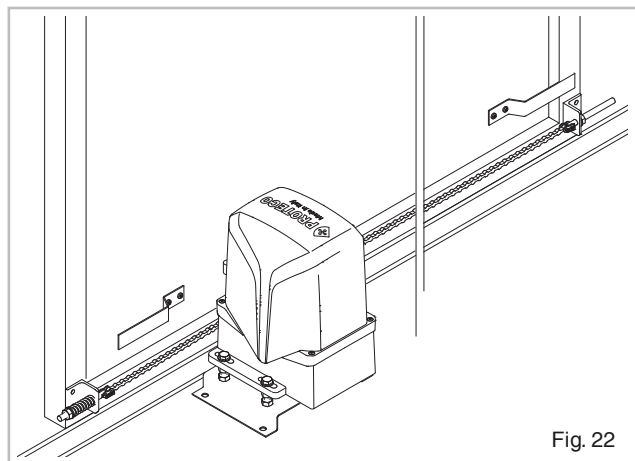
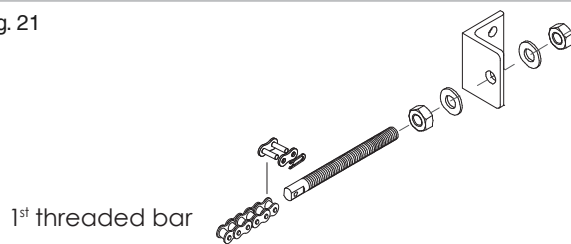

Fig. 22

Fig. 24

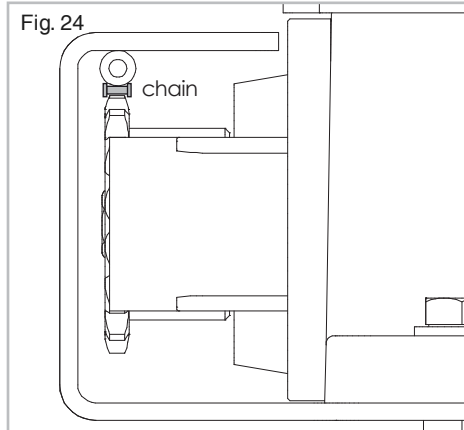
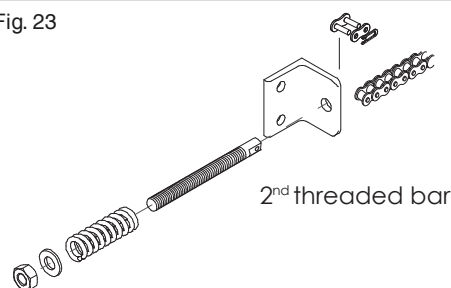

Fig. 23



### 3.7.1 Limit-brackets fixing for chain-driving motor

Please pay attention when fixing limit-brackets, once fixed to the gate no further adjustments are possible. We recommend the following procedure:

- Drive the gate manually to almost complete open/close position, make sure that the gate don't touch its mechanical stop yet.
- Place the limit bracket on the gate and slide it along the gate till it meets the limit-switch.
- Now fix the limit-bracket on the gate and repeat on the other side.

Fig. 25

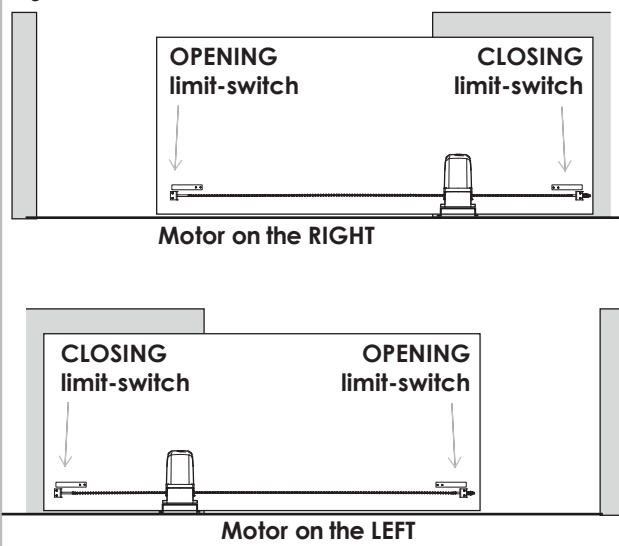
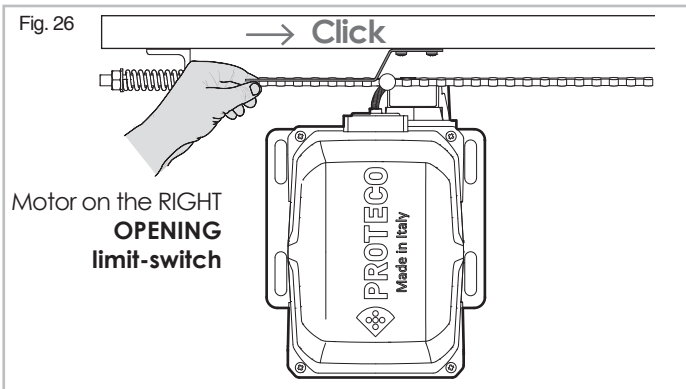
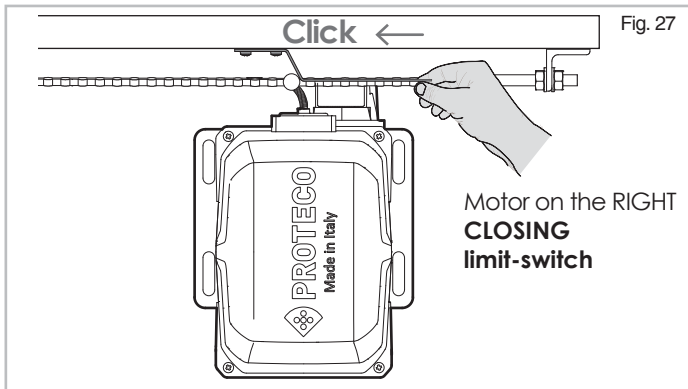

Fig. 26



Motor on the RIGHT  
**OPENING**  
limit-switch

Fig. 27



Motor on the RIGHT  
**CLOSING**  
limit-switch

Once the assembling of the limit brackets to rack is completed, open and close the gate manually to check that the brackets always activate the limit-switch system before the gate reaches its mechanical stops. This checking is important to preserve the correct working of the automation and continued good mechanical condition of the gate.

## 4. ELECTRICAL WIRING

Insert the electrical cables into the control panel's case by piercing the rubber membrane and place the cable grommet in its purpose fabricated seat on the motor's base (Fig. 28).

Follow the control panel's instruction manual to proceed with the correct cable wiring.

## 5. START-UP

Power the system and proceed with a careful checking of the gear motor working and of all the accessories and safety devices connected to the system.

In particular make sure that the electric limit-switch is always activated in opening and closing before the gate reaches its mechanical stops. Lift the motor cover down and close it with the four side screws.

Hand over this instructions manual to the end user and demonstrate the correct use of the automation and how to release the motor for manual operation of the gate in the event of power cuts.

Fig. 28

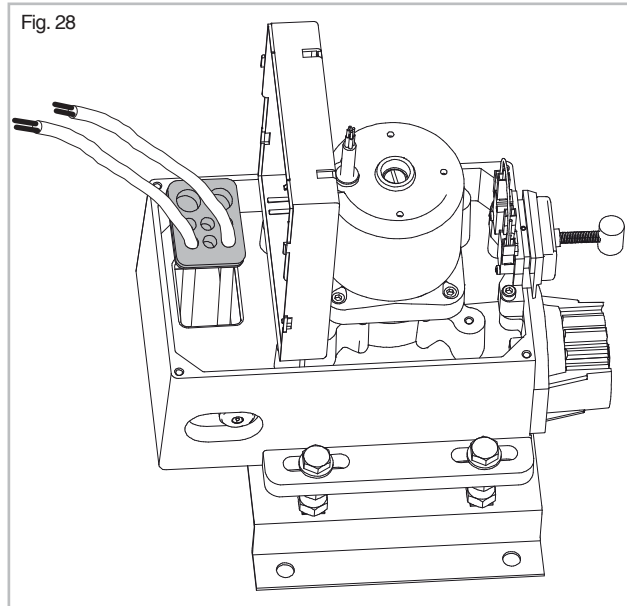

## 6. RELEASE PROCEDURE FOR MANUAL OPERATION

 Always cut the main power of the system during the release and re-locking procedure to avoid any accidental activation of the gate.

### 6.1 How to unlock the motor for manual operating

- a) Insert the key and turn it anti-clockwise (Fig. 29).
- b) Open and close the gate manually as required.

### 6.2 How to restore the automatic working

- a) Turn the key clockwise, take it out.
- b) Manually move the gate until it re-engages the locking system.
- c) Restore power to the automation system.

Fig. 29

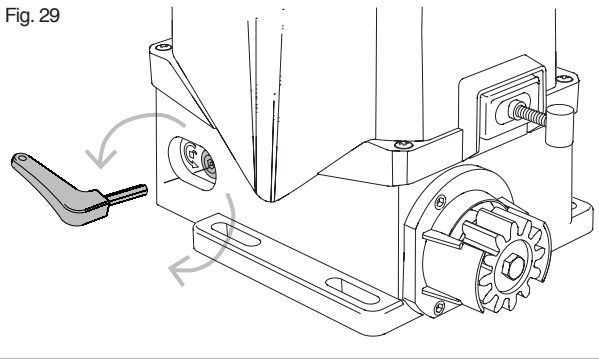

 Always keep the release key together with the instruction manual in a safe place.

## 7. MAINTENANCE

Check the correct working of the automation at least twice a year, pay particular attention to the safety devices, the torque force produced, the release system for manual operation and to all the mechanical moving parts.

Any components displaying significant wear should be obtained from Proteco or associated agents and replaced immediately.

## 8. DISPOSAL

 Do not pollute the environment

Some components may contain polluting substances. Ensure materials are passed to authorised collection centres, according to the laws and the regulations in force in your locality for safe disposal.